

CAD İLE ÇİZİLMİŞTİR. ELDE DEĞİŞTİRMİYİN. RESİM ÜZERİNDEN OLCU ALMAYINIZ.

S.A	K.K	D.T	P.R	P.M	K.H	AB	CNC	MN3	EN3
○	○	○	○	○	○	○	○	○	○

KALIP / TOOL NO :

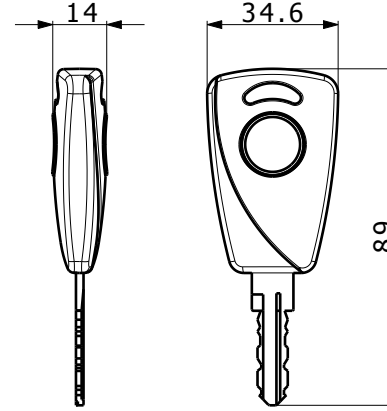
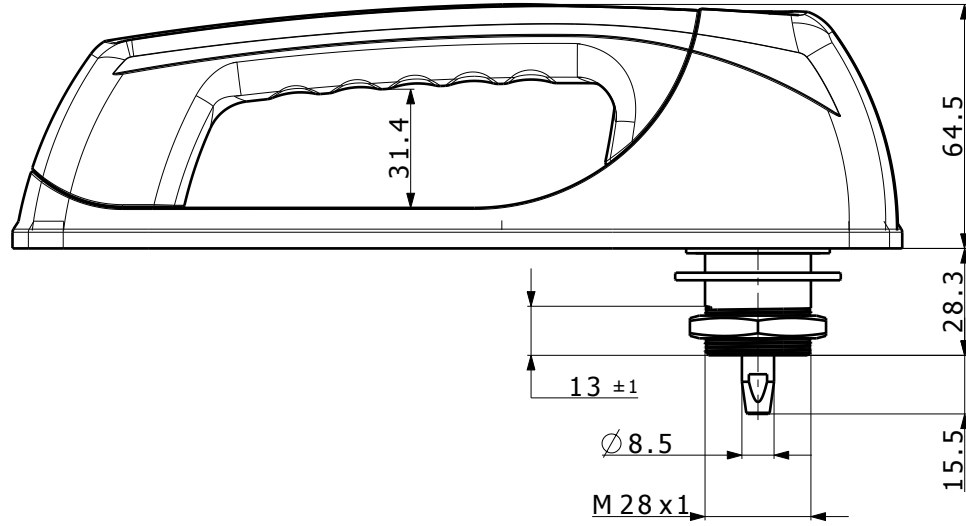
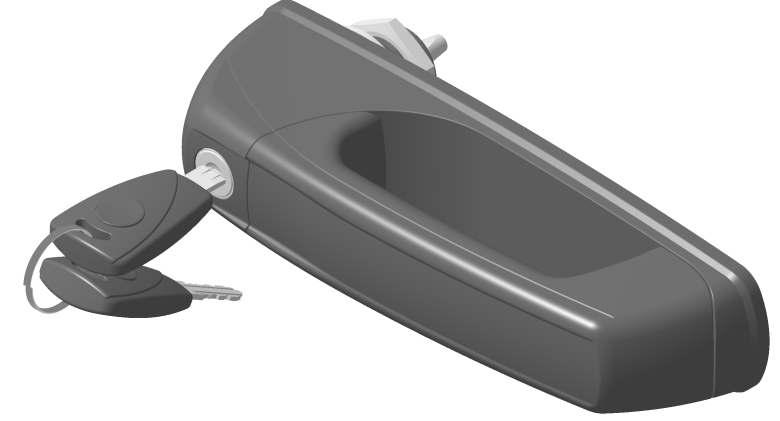
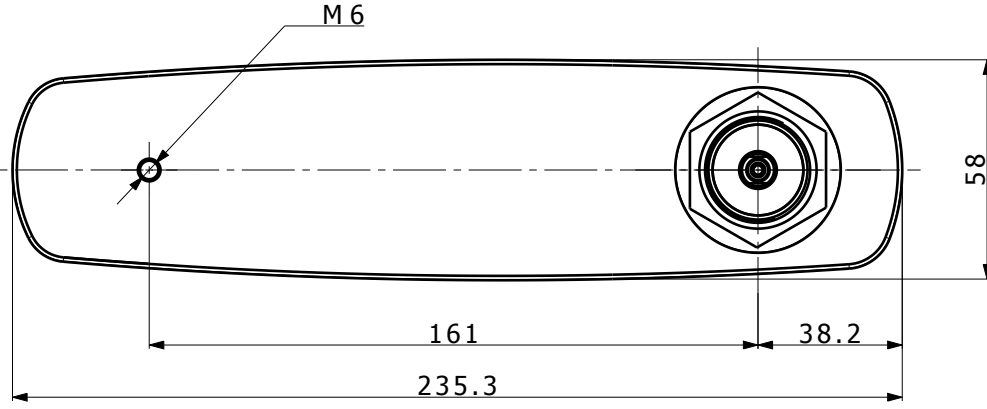

STROK: 18mm±1

				İSİM NAME	TARİH DATE	İMZA SIGN	Ref. Parça-Benzer Parca No/ Ref. Part/Similar part:	Malzeme / Material:			
			Çizen Drawn By	M.YILDIZ	31.08.20						
			Tasarım Design Check	E.ÇOLAK			Müs. No/Cus Code:	Parça Adı /Part Name: ÇEKME Lİ KULP(PULL HANDLE)			
			Kontrol Control	M.ÖZMEN			Grup Kod / Group Code:	Parça No: /Part Number: 2841			
			Onay Approval	O.KLIRÇIVALOĞLU			Genel toleranslar ISO 2768-cK General tolerances				
For prototype	P1	31.08.20	M.Y.	Görsel Sınıf: Visual Cls :	Emn. Sınıfı: Safety Class: B	Ölçek/Scale: 1:2		Ağırlık/Weight:	Rev. No.	Rfp. No.	Sayfa No: Page Nr: 1
REVİZYON / CHANGES	REV	Tarih/Date	ÇİZEN	First Angle Projection ISO 5456		Sistem/System Catia V5			P1		